

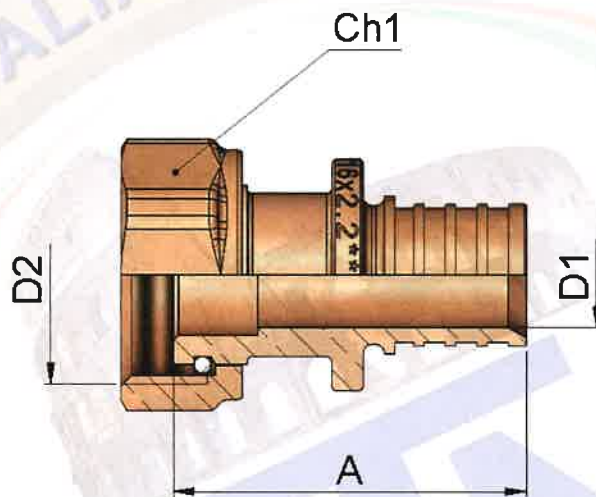

## SCHEDA TECNICA / DATA SHEET

### Art. 4635

*Adattatore con tenuta sede piana*  
*Adapter flat washer connection*



Misura Size	Spessore Thick.	D1 [mm]	D2 [mm]	A [mm]	Ch1 [mm]
16x1/2	2.2	10	1/2	33,5	24
16x3/4	2.2	10	3/4	35,5	30
20x1/2	2.8	12,5	1/2	35,5	24
20x3/4	2.8	12,5	3/4	40	30