

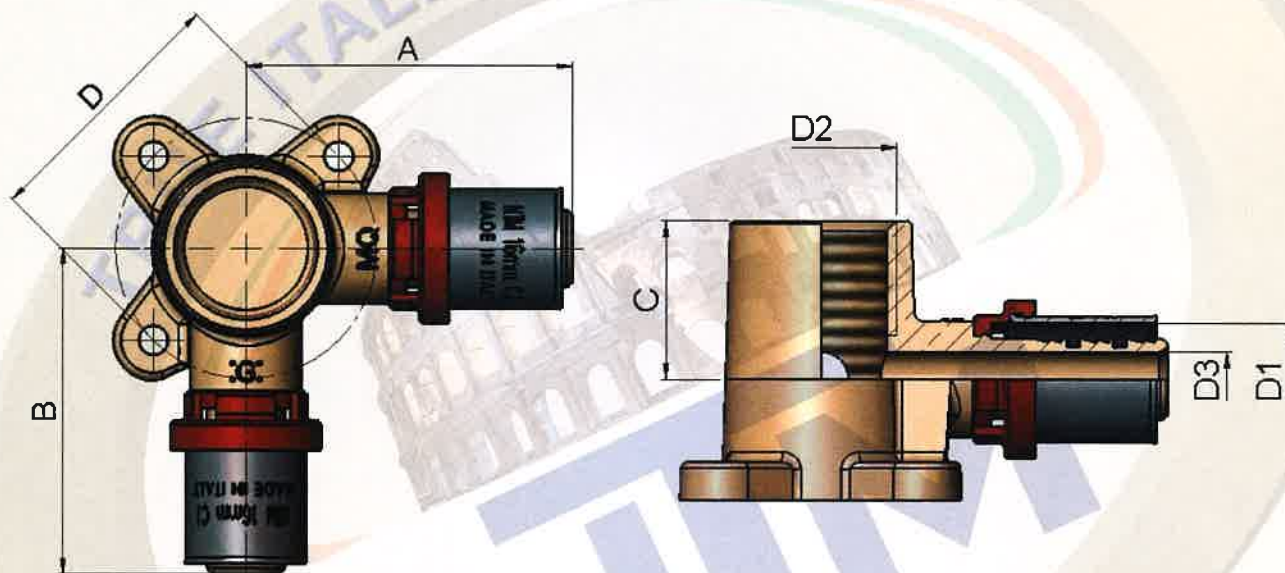

## SCHEDA TECNICA / DATA SHEET

### Art. 726-V

*Raccordo con flangia doppio*  
*Double wallplate elbow*



Misura Size	Spessore Thick.	D1 [mm]	D2 [mm]	D3 [mm]	A [mm]	B [mm]	C [mm]	D [mm]
16x1/2x16	2.0	16	1/2	8	50.0	50.0	23.0	40.0
20x1/2x20	2.0	20	1/2	11.5	50.0	50.0	24.0	40.0