

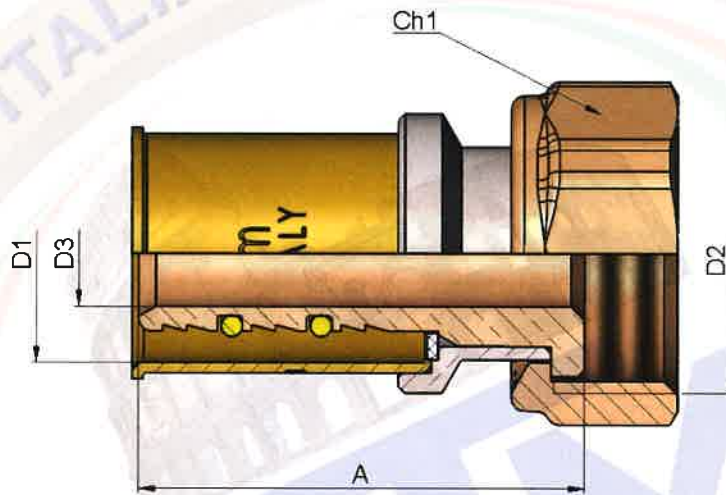

## SCHEMA TECNICA / DATA SHEET

### Art. 735-G

*Adattatore a pressare con tenuta sede piana*  
*Press adapter flat washer connection*



Misura Size	Spessore Thick.	D1 [mm]	D2 [mm]	D3 [mm]	A [mm]	Ch1 [mm]
16x1/2	2.0	16.0	1/2	8.0	33.5	24.0
16x3/4	2.0	16.0	3/4	8.0	33.5	30.0
20x1/2	2.0	20.0	1/2	11.5	32.5	24.0
20x3/4	2.0	20.0	3/4	11.5	32.5	30.0
26x3/4	3.0	26.0	3/4	15.0	34.5	30.0

